

# GAMESA G80-2.0 MW



# BENEFITS

**Maximum unit power with excellent performance for high winds**

- **Class IA/WZII/WZIII.**
- **Pitch and variable speed technology to maximize energy production.**
- **Production of lighter blades using fiberglass and prepreg method.**
- **Compliance with the main international Grid Codes.**
- **Aerodynamic design and Gamesa NRS™ control system to minimize noise emissions.**
- **Gamesa SGIPE: Remote monitoring and control system with Web access.**



## Rotor

Diameter	80 m
Swept area	5,027 m <sup>2</sup>
Rotational speed	9.0 - 19.0 rpm
Rotational direction	Clock Wise (front view)
Weight (incl. Hub)	Approx. 38 T
Top head mass	Approx. 108 T

## Blades

Number of blades	3
Length	39 m
Airfoils	NACA 63.XXX + FFA-W3
Material	Glass fiber reinforced with epoxy resin
Total blade weight	6,500 kg

## Tubular Tower

Modular type	Height	Weight
3 sections	60 m	127 T
3 sections	67 m	145 T
4 sections	78 m	201 T
5 sections	100 m	283 T

## Gearbox

Type	1 planetary stage / 2 parallel stages
Ratio	1:100.5 (50 Hz) 1:120.5 (60 Hz)
Cooling	Oil pump with oil cooler
Oil heater	2.2 kW

## Generator 2.0 MW

Type	Doubly-fed machine
Rated power	2.0 MW
Voltage	690 V ac
Frequency	50 Hz / 60 Hz
Protection class	IP 54
Number of poles	4
Rotational speed	900:1,900 rpm (rated 1,680 rpm) (50 Hz) 1,080:2,280 rpm (rated 2,016 rpm) (60 Hz)
Rated Stator Current	1,500 A @ 690 V
Power factor (standard)	0.98 CAP - 0.96 IND at partial loads and 1 at nominal power. *
Power factor (optional)	0.95 CAP - 0.95 IND throughout the power range. *

\* Power factor at generator output terminals, at low voltage side before transformer input terminals.

## Mechanical design

Drive train with main shaft supported by two spherical bearings that transmit the side loads directly to the frame by means of the bearing housing. This prevents the gearbox from receiving additional loads, reducing malfunctions and facilitating its service.

## Brake

Aerodynamic primary brake by means of full-feathering blades. In addition, a hydraulically-activated mechanical disc brake for emergencies is mounted on the gearbox high speed shaft.

## Lightning protection

The Gamesa G80-2.0 MW wind turbine generator uses the “total lightning protection” system, in accordance with standard IEC 61024-1. This system conducts the lightning from both sides of the blade tip down to the root joint and from there across the nacelle and tower structure to the grounding system located in the foundations. As a result, the blade and sensitive electrical components are protected from damage.

## Control System

- The Generator is a doubly fed machine (DFM), whose speed and power is controlled through IGBT converters and PWM (Pulse Width Modulation) electronic control.
- Benefits:
  - Active and reactive power control.
  - Low harmonic content and minimal losses.
  - Increased efficiency and production.
  - Prolonged working life of the turbine.

## Gamesa SGIPE

Gamesa SGIPE and its new generation Gamesa WindNet™ (wind farm control systems), developed by Gamesa, that allow realtime operation and remote control of wind turbines, meteorological mast and electrical substation via satellite-terrestrial network. Modular design with control tools for active and reactive energy, noise, shadows and wake effects. TCP/IP architecture with a Web interface.

## SMP Predictive Maintenance System

Predictive Maintenance System for the early detection of potential deterioration or malfunctions in the wind turbine's main components.

- Benefits:
  - Reduction in major corrective measures.
  - Increase in the machine's availability and working life.
  - Preferential terms in negotiations with insurance companies.
  - Integration within the control system.

## Noise control

Aerodynamic blade tip and mechanical component design minimize noise emissions. In addition, Gamesa has developed the Gamesa NRS™ noise control system, which permits programming the noise emissions according to criteria such as date, time or wind direction. This achieves the goals of local regulation compliance as well as maximum production.

## Grid connection

Gamesa's doubly-fed wind turbines and Active Crowbar and over sized converter technologies ensure the compliance with the most demanding grid connection requirements.

Low voltage ride-through capability and dynamic regulation of active and reactive power.

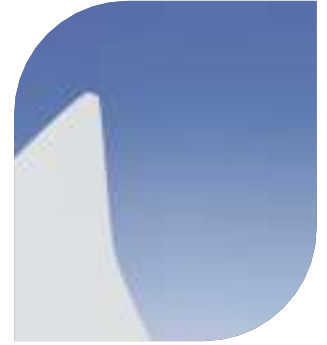
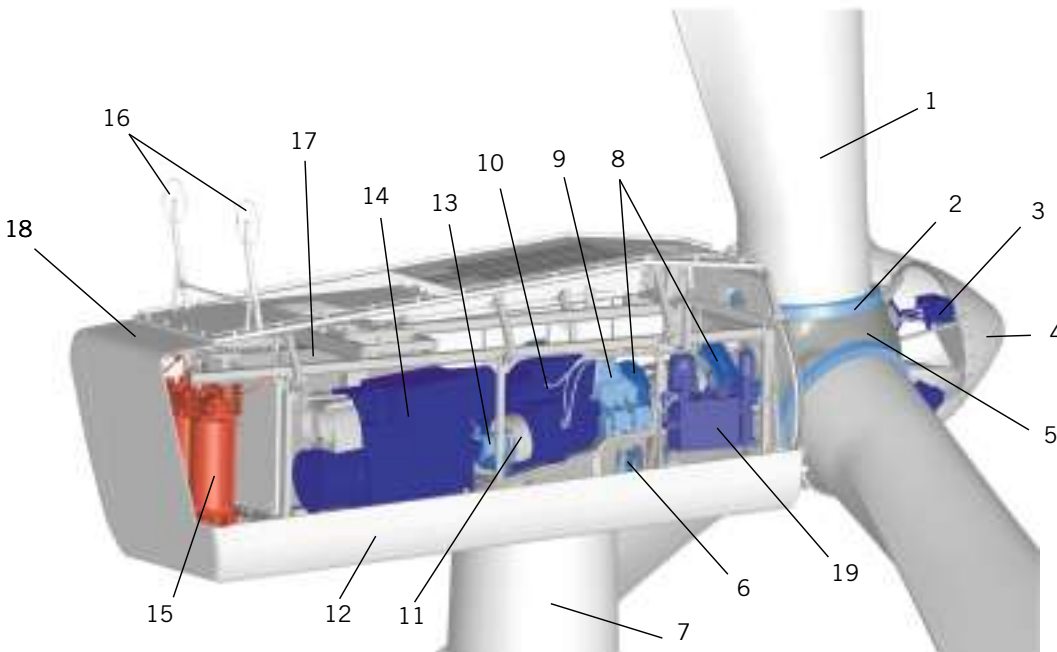

- 1. Blade
- 2. Blade bearing
- 3. Hydraulic pitch actuator
- 4. Hub cover
- 5. Hub

- 6. Active yaw control
- 7. Tower
- 8. Main shaft with two bearing houses
- 9. Shock absorbers

- 10. Gearbox
- 11. Main disc brake
- 12. Nacelle support frame
- 13. Transmission: High speed shaft
- 14. Doubly fed generator

- 15. Transformer
- 16. Anemometer and wind vane
- 17. Top controller
- 18. Nacelle cover
- 19. Hydraulic unit

## Power Curve Gamesa G80-2.0 MW (for an air density of 1,225 kg/m<sup>3</sup>)

Power curve calculation based on NACA 63.XXX and FFA-W3 air-foils.

Calculation parameters: 50 Hz grid frequency; tip angle pitch regulated; 10% turbulence intensity and a variable rotor speed ranging from 9.0 - 19.0 rpm.

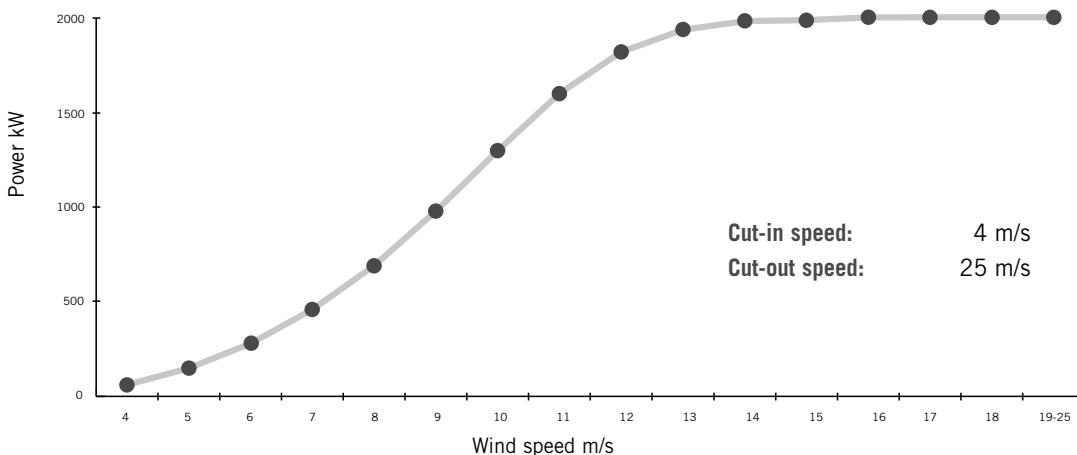

Speed (m/s)	Power (kW)
4	66.3
5	152.0
6	280.0
7	457.0
8	690.0
9	978.0
10	1296.0
11	1598.0
12	1818.0
13	1935.0
14	1980.0
15	1995.0
16	1999.0
17	2000.0
18	2000.0
19-25	2000.0



Polígono Industrial Agustinos, C/A s/n  
31013 Pamplona, Spain  
Tel: +34 948 309010  
Fax: +34 948 309009  
info@eolica.gamesa.es  
www.gamesa.es

**Gamesa Wind GmbH**

Wailandtstrasse 7  
63741 Aschaffenburg  
Germany  
Tel: +49 (0) 6021 15 09 0  
Fax: +49 (0) 6021 15 09 199  
E-mail: info@wind.gamesa.de

**Gamesa Wind Engineering**

Vejlsøvej 51  
8600 Silkeborg  
Denmark  
Tel: +45 87 229205 / 9204  
Fax: +45 87 229201

**France**

Parc Mail  
6 Allée Joliot Curie, bâtiment B  
69791 Saint Priest  
Tel: +33 (0) 472 79 47 09  
Fax: +33 (0) 478 90 05 41

**Greece**

3, Pampouki Street  
154 51 Neo Psychiko  
Athens  
Tel: +30 21 06753300  
Fax: +30 21 06753305

**Gamesa Eolica Italia**

Via Pio Emanuelli, 1  
Corpo B, 2° piano  
00143 Rome  
Tel: +39 0651531036  
Fax: +39 0651530911

**Portugal**

Edifício D. João II  
PARQUE DAS NAÇÕES  
Av. D. João II, lote 1.06.2.3-7° B  
1990-090 Lisbon  
Tel: +351 21 898 92 00  
Fax: +351 21 898 92 99

**United Kingdom**

Rowan House Hazell Drive  
NEWPORT South Wales NP10 8FY  
Tel: +44 1633 654 140  
Fax: +44 1633 654 147

**Gamesa Wind US**

1 Ben Fairless Drive - Ste. 2  
Fairless Hills, PA 19030  
Tel: +1 215 736 8165  
Fax: +1 215 736 3985

**Gamesa Wind Tianjin**

Room 1103, Tower 1  
Bright China  
Changan Building  
7 Jianguomennei Av.  
Beijing 100005  
China  
Tel.: +86 10 65186158  
Fax: +86 10 65171337

